

# Cisco 1750 Router Overview

---

This chapter introduces the Cisco 1750 router, also referred to in this guide as “the router,” and covers the following topics:

- Key Features
- Rear-Panel Ports and LEDs
- Front-Panel LEDs
- Router Memory
- Unpacking the Router
- Additional Required Equipment

## Key Features

---

Figure 1-1 shows the Cisco 1750 router.

**Figure 1-1 Cisco 1750 Router**

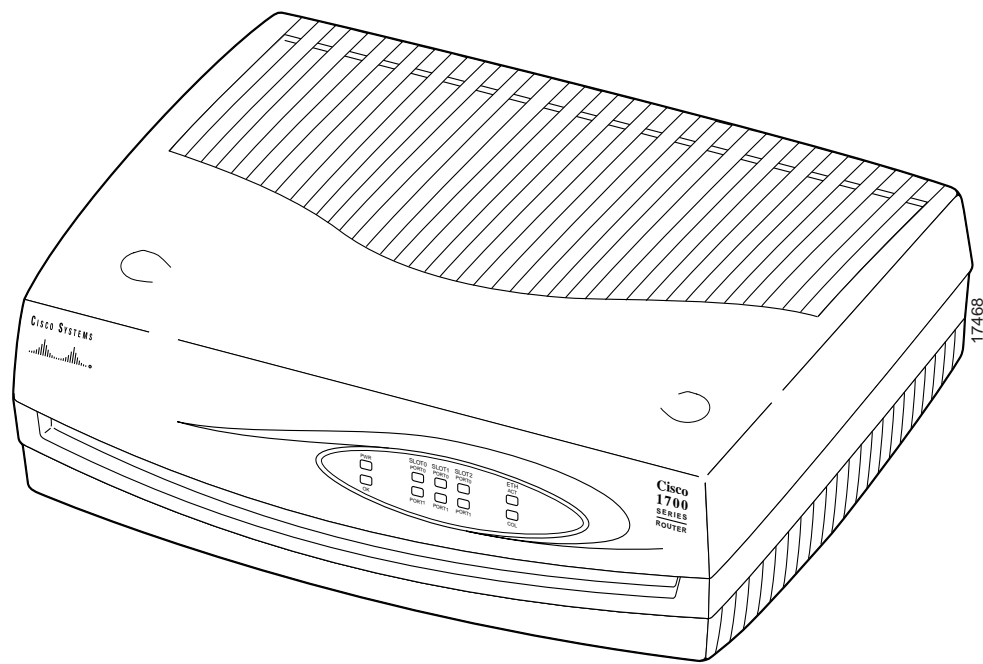

## Key Features

The Cisco 1750 router is a voice-and-data capable router that provides Voice-over-IP functionality (VoIP) and can carry voice traffic (for example, telephone calls and faxes) over an IP network. Using one to four WAN connections, the router links small-to-medium-size remote Ethernet and FastEthernet LANs to central offices. Table 1-1 lists the router key features.

**Table 1-1 Key Features**

| <b>Feature</b>                               | <b>Description</b>   |
|--|--|
| One FastEthernet (10/100BaseTX) port         | <ul style="list-style-type: none"> <li>Operates in full- or half-duplex mode (with manual override available).</li> <li>Supports autosensing for 10- or 100-Mbps operation.</li> </ul>   |
| Cisco interface cards                        | <ul style="list-style-type: none"> <li>Supports two slots for either WAN interface cards (WICs) or voice interface cards (VICs).</li> <li>Supports one VIC-only slot.</li> <li>Supports the following WICs: ISDN BRI (U and S/T), 56- or 64-kbps DSU/CSU, FT1/T1 DSU/CSU, high-speed serial, dual-serial, and 2Async/Sync.</li> <li>Supports the following VICs: 2FXS, 2FXO, 2E&amp;M.</li> <li>Changes in WAN interface configuration can be made as your network requirements change.</li> </ul> |
| Console port                                 | Supports router configuration and management from a connected terminal or PC. Supports up to 115.2 kbps.   |
| Auxiliary port                               | Supports modem connection to the router, which can be configured and managed from a remote location. Supports up to 115.2 kbps.  |
| Security slot                                | Supports Kensington or similar lockdown equipment.   |
| SNMP support                                 | Supports Simple Network Management Protocol (SNMP) to manage the router over a network.  |
| AutoInstall support                          | Supports AutoInstall to download configuration files to the router over a WAN connection.  |
| Cisco ConfigMaker support                    | Supports Cisco ConfigMaker application, a wizards-based software tool, to configure a network that includes the Cisco 1750 router.   |
| Cisco Voice Manager support                  | Supports Cisco Voice Manager to help you install and operate voice and fax services over the IP network.   |
| Compatible with Cisco Networked Office stack | Stackable with other Cisco Networked Office stack products.  |

## Rear-Panel Ports and LEDs

This section describes the router rear-panel ports and LEDs, which are shown in Figure 1-2 and described in Table 1-2 and Table 1-3.

**Figure 1-2 Rear-Panel Components and LEDs**

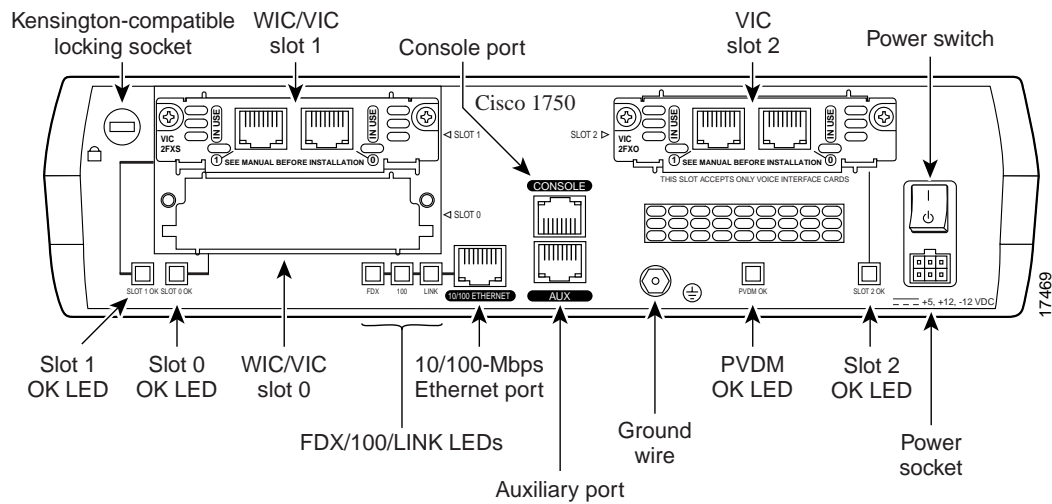

**Table 1-2 Rear-Panel Connectors**

| Connector/Slot | Label/Color                         | Description   |
|----------------|-------------------------------------|---|
| Ethernet port  | 10/100-Mbps<br>ETHERNET<br>(yellow) | Router connection to the local Ethernet network. This port autosenses the speed (10 or 100 Mbps) and duplex mode (full or half) of the device to which it is connected and then operates at the same speed and in the same duplex mode. |
| Auxiliary port | AUX<br>(black)                      | Modem connection for remote configuration using Cisco IOS software.   |
| Console port   | CONSOLE<br>(light blue)             | Terminal or PC connection for local configuration using Cisco IOS software.   |

**Table 1-2 Rear-Panel Connectors (Continued)**

| Connector/Slot   | Label/Color      | Description   |
|------------------|------------------|---|
| WIC/VIC slot     | SLOT 0           | Supports either a Cisco WIC or VIC. For detailed information, refer to the <i>Cisco WAN Interface Cards Hardware Installation Guide</i> that comes with every card. |
| WIC/VIC slot     | SLOT 1           | Supports either a Cisco WIC or VIC. For detailed information, refer to the <i>Cisco WAN Interface Cards Hardware Installation Guide</i> that comes with every card. |
| VIC slot         | SLOT 2           | Supports one Cisco VIC. For detailed information, refer to the <i>Cisco WAN Interface Cards Hardware Installation Guide</i> that comes with every card.             |
| Power socket     | +5, +12, -12 VDC | Router connection to the external power supply.   |
| Protective earth | Ground wire      | Router connection to earth ground by using a green and yellow 14 AWG ground wire.   |

Use the rear-panel LEDs during router installation to confirm that you have correctly connected all cables to the router.

**Table 1-3 Rear-Panel LEDs**

| LED Label | Color | Description   |
|-----------|-------|---|
| FDX       | Green | On—Ethernet port is operating in full-duplex mode.<br>Off—Ethernet port is operating in half-duplex mode. |
| 100       | Green | On—Ethernet port is operating at 100 Mbps.<br>Off—Ethernet port is operating at 10 Mbps.                  |
| LINK      | Green | On when the Ethernet link is up.  |
| SLOT 0 OK | Green | On when either a WIC or VIC is correctly inserted in the card slot.                                       |
| SLOT 1 OK | Green | On when either a WIC or VIC is correctly inserted in the card slot.                                       |
| SLOT 2 OK | Green | On when a VIC is correctly inserted in the card slot.   |
| PVDM OK   | Green | On when a packet voice data module (PVDM) is correctly inserted in the card slot.                         |

## Front-Panel LEDs

Use the router front-panel LEDs to determine network activity and status on the Ethernet port and on the WIC and VIC ports. The front-panel LEDs are illustrated in Figure 1-3 and described in Table 1-4.

**Figure 1-3 Front-Panel LEDs**

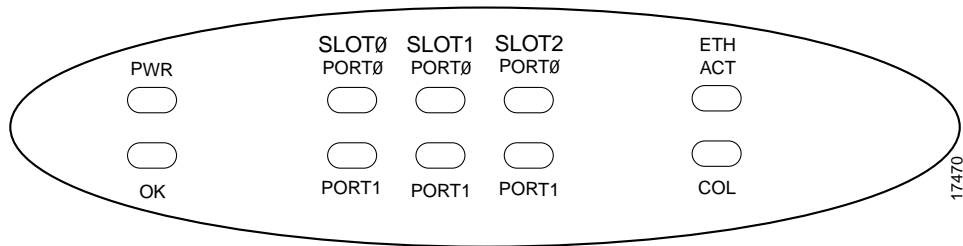

**Table 1-4 Front-Panel LEDs**

| LED | Color  | Cards Supported | LED Meaning   |
|-----|--------|-----------------|---|
| PWR | Green  | –               | On when DC power is being supplied to the router.   |
| OK  | Green  | –               | On when the router has successfully booted up and the software is functional. This LED blinks during the power-on self-test (POST).<br>Refer to Table 3-2 in the “Troubleshooting” chapter for information on how to use this LED for router diagnostics. |
| ETH |        |                 |   |
| ACT | Green  | –               | Blinks when there is network activity on the Ethernet port.   |
| COL | Yellow | –               | Blinks when there are packet collisions on the local Ethernet network.  |

**Table 1-4 Front-Panel LEDs (Continued)**

| LED   | Color | Cards Supported    | LED Meaning  |
|-------|-------|--------------------|--|
| SLOTØ |       |                    |  |
| PORTØ | Green | ISDN               | On when the first ISDN B channel is connected.               |
|       |       | Serial and CSU/DSU | Blinks when data is being sent to or received from the port. |
|       |       | 2-port serial      |  |
|       |       | VIC-2E&M           |  |
|       |       | VIC-2FXO           |  |
|       |       | VIC-2FXS           |  |
| PORT1 | –     | Serial and CSU/DSU | Off.   |
|       | Green | ISDN               | On when the first ISDN B channel is connected.               |
|       |       | 2-port serial      | Blinks when data is being sent to or received from the port. |
|       |       | VIC-2E&M           |  |
|       |       | VIC-2FXO           |  |
|       |       | VIC-2FXS           |  |

## Front-Panel LEDs

**Table 1-4 Front-Panel LEDs (Continued)**

| LED   | Color | Cards Supported    | LED Meaning  |
|-------|-------|--------------------|--|
| SLOT1 |       |                    |  |
| PORTØ | Green | ISDN               | On when the first ISDN B channel is connected.               |
|       |       | Serial and CSU/DSU | Blinks when data is being sent to or received from the port. |
|       |       | 2-port serial      |  |
|       |       | VIC-2E&M           |  |
|       |       | VIC-2FXO           |  |
|       |       | VIC-2FXS           |  |
| PORT1 | –     | Serial and CSU/DSU | Off.   |
|       | Green | ISDN               | On when the first ISDN B channel is connected.               |
|       |       | 2-port serial      | Blinks when data is being sent to or received from the port. |
|       |       | VIC-2E&M           |  |
|       |       | VIC-2FXO           |  |
|       |       | VIC-2FXS           |  |
| SLOT2 |       |                    |  |
| PORTØ | Green | VIC-2E&M           | Blinks when data is being sent to or received from the port. |
|       |       | VIC-2FXO           |  |
|       |       | VIC-2FXS           |  |
| PORT1 | Green | VIC-2E&M           | Blinks when data is being sent to or received from the port. |
|       |       | VIC-2FXO           |  |
|       |       | VIC-2FXS           |  |



## Router Memory

This section describes the types of memory stored in the router and how to find out how much of each the router has.

For instructions on how to upgrade memory in the router, refer to the “Installing and Upgrading Memory and Data Modules” appendix in this guide.

## Types of Memory

The router has the following types of memory:

- **Dynamic RAM (DRAM)**—This is the main storage memory for the router. DRAM is also called working storage and contains the dynamic configuration information. The router stores a working copy of Cisco IOS software, dynamic configuration information, and routing table information in DRAM.
- **Nonvolatile RAM (NVRAM)**—This type of memory contains the startup configuration.
- **Flash memory**—This special kind of erasable, programmable memory contains a copy of the Cisco IOS software. The Flash memory structure can store multiple copies of the Cisco IOS software. You can load a new level of the operating system in every router in your network and then, when convenient, upgrade the whole network to the new level. The Flash memory on the router is stored on mini-Flash modules.

### Amounts of Memory

Use the **show version** command to view the amount of DRAM, NVRAM, and Flash memory stored in your router. The following example shows the output of the **show version** command. The bold text displays the amount of memory stored in this router.

```
1750# show version
Cisco Internetwork Operating System Software
IOS (tm) C1700 Software (C1700-SV3Y-M), Experimental Version
12.0(19980308:184442) [syaji-grammy-v6 189]
Copyright (c) 1986-1999 by cisco Systems, Inc.
Compiled Mon 22-Mar-99 12:58 by syaji
Image text-base: 0x80008088, data-base: 0x806B2BB8

ROM: System Bootstrap, Version 12.0(1)XA1,RELEASE SOFTWARE (fc1)

Router uptime is 15 minutes
System restarted by power-on
System image file is "flash:syaji/c1700-sv3y-mz"

cisco 1750 (MPC860) processor (revision 0x00) with 24576K/8192K bytes of
memory.
Processor board ID 0000 (1314672220), with hardware revision 0000
M860 processor: part number 0, mask 32
Bridging software.
X.25 software, Version 3.0.0.
1 FastEthernet/IEEE 802.3 interface(s)
2 Low-speed serial(sync/async) network interface(s)
2 Voice FXS interface(s)
2 Voice E & M interface(s)
32K bytes of non-volatile configuration memory.
8192K bytes of processor board System flash (Read/Write)

Configuration register is 0x0
```

## Unpacking the Router

Figure 1-4 shows the items that come with your router. All of these are in the accessory kit that is inside the box that your router came in.

Figure 1-4 Router Box Contents

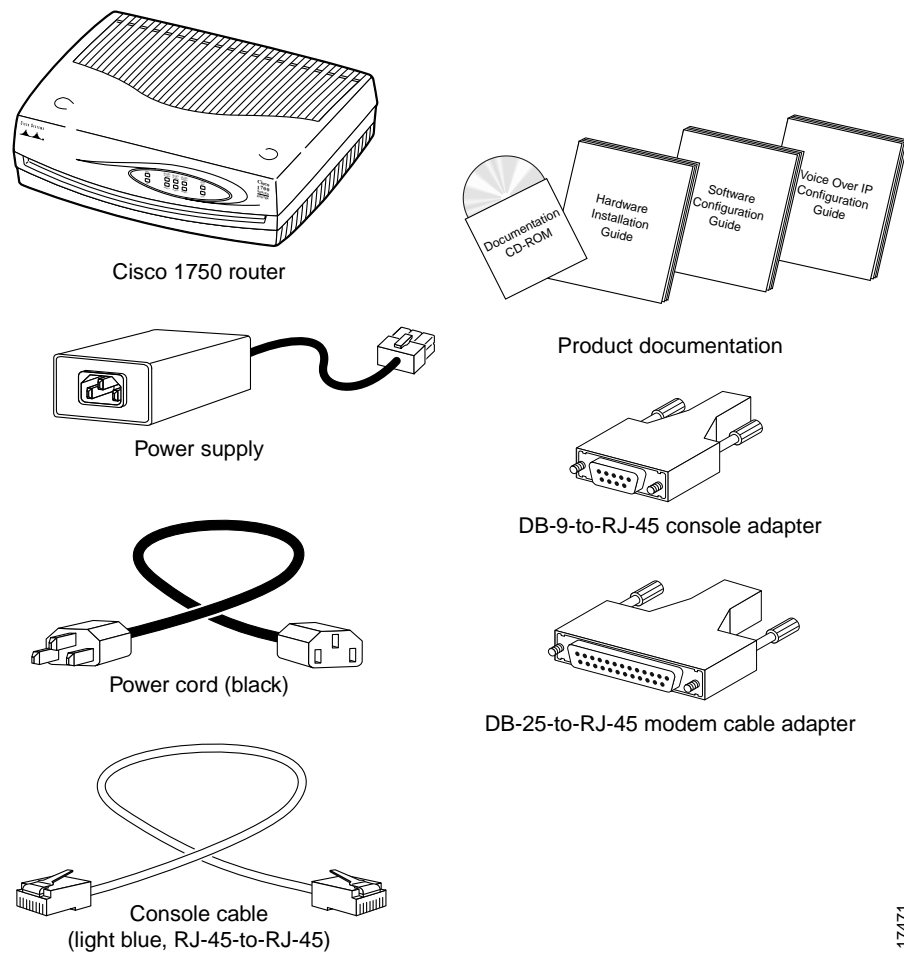

17471

# Additional Required Equipment

Depending on your local network and which Cisco WICs and VICs you install in your router, you might need other items listed in Table 1-5 to complete your router installation.

**Table 1-5 Additional Required Equipment**

| <b>Equipment</b>                      | <b>When You Use It</b>  |
|---------------------------------------|---|
| Ethernet hub                          | A hub connects pieces of network equipment (including the router) to create a network. You can use a 10-, 100-, or 10/100-Mbps hub with the router.   |
| Ethernet switch                       | A switch connects pieces of network equipment (including the router) to create a network. You can use a 10-, 100-, or 10/100-Mbps switch with the router.   |
| Phillips screwdriver                  | Although the WICs and VICs use thumbscrews, you might need a Phillips screwdriver to loosen the WIC and VIC cover.  |
| Cisco WIC                             | To make a WAN connection, the router must have a supported WIC installed. The router supports up to two cards. You can either order the cards when ordering the router, and they will be installed for you, or you can order the cards separately, after receiving the router, and install them yourself.     |
| Cisco VIC                             | To make a voice connection, the router must have a supported VIC installed. The router supports up to three cards. You can either order the cards when ordering the router, and they will be installed for you, or you can order the cards separately, after receiving the router, and install them yourself. |
| Straight-through RJ-45-to-RJ-45 cable | This cable connects the router to the Ethernet LAN and the WICs to various WAN services, including ISDN, T1/FT1, and 56-kbps services. You will need one cable for each of these connections.   |
| Standard RJ-11 telephone cable        | This cable connects the VIC to a telephone, fax machine, or a telephone wall-jack. You will need one cable for each of these connections.   |
| Standard RJ-48 telephone cable        | This cable connects the VIC to a PBX trunk line. You will need one cable for each of these connections.   |

**Table 1-5 Additional Required Equipment (Continued)**

| <b>Equipment</b>   | <b>When You Use It</b>   |
|--------------------|--|
| Serial cable       | This cable connects a serial card to serial services. You must order this cable from Cisco. For detailed information about serial cable types, refer to the <i>Cisco WAN Interface Cards Hardware Installation Guide</i> that comes with every card. |
| NT1                | Some ISDN service providers require a Network Termination 1 device to connect an ISDN S/T port to the ISDN line.   |
| Asynchronous modem | To configure the router from a remote location, connect a modem to the AUX port on the router.   |

## **Additional Required Equipment**

---